

COATS®

Model 1300-2D

Wheel Balancer



See
★ **Balancing Your
First Tire**
on page 4.

Safety Instructions

Set-up Instructions

Operation Instructions

Maintenance Instructions

READ these instructions before placing unit in service. KEEP these and other materials delivered with the unit in a binder near the machine for ease of reference by supervisors and operators.

HENNESSY
INDUSTRIES

1601 J. P. Hennessy Drive, LaVergne, TN USA 37086 615/641-7533 800/688/6359 www.coatsgarage.com
HENNESSY INDUSTRIES INC. Manufacturer of AMMCO®, COATS® and BADA® Automotive Service Equipment and Tools.

Manual Part No.: 85610936 00
Revision: 12/16

IMPORTANT SAFETY INSTRUCTIONS

READ ALL INSTRUCTIONS

1. Eye and face protection recommendations:
“Protective eye and face equipment is required to be used where there is a reasonable probability of injury that can be prevented by the use of such equipment.” O.S.H.A. 1910.133(a) Protective goggles, safety glasses, or a face shield must be provided by the owner and worn by the operator of the equipment. Care should be taken to see that all eye and face safety precautions are followed by the operator. ALWAYS WEAR SAFETY GLASSES. Everyday glasses only have impact resistant lenses, they are not safety glasses.
2. Do not disable hood safety interlock system, or in any way shortcut safety controls and operations.
3. Be sure that wheels are mounted properly, the hub nut engages the arbor for not less than four (4) turns, and the hub nut is firmly tightened before spinning the wheel.
4. Read and understand this manual before operating. Abuse and misuse will shorten the functional life.
5. Be sure the balancer is properly connected to the power supply and electrically grounded.
6. Do not operate equipment with a damaged cord or if the equipment has been dropped or damaged – until it has been examined and repaired by a qualified serviceman.
7. Do not let cord hang over edge of table, bench, or counter or come in contact with hot manifolds or moving fan blades.
8. If an extension cord is necessary, a cord with a current rating equal to or more than that of the equipment should be used. Cords rated for less current than the equipment may overheat. Care should be taken to arrange the cord so that it will not be tripped over or pulled.
9. Keep guards and safety features in place and in working order.
10. Wear proper clothing. Safety toe, non-slip footwear and protective hair covering to contain hair is recommended. Do not wear jewelry, loose clothing, neckties, or gloves when operating the balancer.
11. Keep work area clean and well lighted. Cluttered and/or dark areas invite accidents.
12. Avoid dangerous environments. Do not use power tools or electrical equipment in damp or wet locations, or expose them to rain.
13. Avoid unintentional starting. Be sure the balancer is turned off and power disconnected before servicing.
14. Disconnect the balancer before servicing.
15. Use only manufacturer’s recommended accessories. Improper accessories may result in personal injury or property damage.
16. Repair or replace any part that is damaged or worn and that may cause unsafe balancer operation. Do not operate damaged equipment until it has been examined by a qualified service technician.
17. Never overload or stand on the weight tray or any part of the balancer.
18. Do not allow untrained persons to operate machinery.
19. To reduce the risk of fire, do not operate equipment in the vicinity of open containers or flammable liquids (gasoline).
20. Adequate ventilation should be provided when working on or operating internal combustion engines.
21. Keep hair, loose clothing, fingers, and all parts of body away from moving parts.
22. Use equipment only as described in this manual.
23. Use only manufacturer’s recommended attachments and accessories.

SAVE THESE INSTRUCTIONS

Owner's Responsibility

To maintain machine and user safety, the responsibility of the owner is to read and follow these instructions:

- Follow all installation instructions.
- Make sure installation conforms to all applicable Local, State, and Federal Codes, Rules, and Regulations; such as State and Federal OSHA Regulations and Electrical Codes.
- Carefully check the unit for correct initial function.
- Read and follow the safety instructions. Keep them readily available for machine operators.
- Make certain all operators are properly trained, know how to safely and correctly operate the unit, and are properly supervised.
- Allow unit operation only with all parts in place and operating safely.
- Carefully inspect the unit on a regular basis and perform all maintenance as required.
- Service and maintain the unit only with authorized or approved replacement parts.
- Keep all instructions permanently with the unit and all decals/labels/notices on the unit clean and visible.
- Do not override safety features.

Operator Protective Equipment

Personal protective equipment helps make tire servicing safer. However, equipment does not take the place of safe operating practices. Always wear durable work clothing during tire service activity. Loose fitting clothing should be avoided. Tight fitting leather gloves are recommended to protect operator's hands when handling worn tires and wheels. Sturdy leather work shoes with steel toes and oil resistant soles should be used by tire service personnel to help prevent injury in typical shop activities. Eye protection is essential during tire service activity. Safety glasses with side shields, goggles, or face shields are acceptable. Back belts provide support during lifting activities and are also helpful in providing operator protection. Consideration should also be given to the use of hearing protection if tire service activity is performed in an enclosed area, or if noise levels are high.

Definitions of Hazard Levels

Identify the hazard levels used in this manual with the following definitions and signal words:

DANGER

Watch for this symbol:



It Means: Immediate hazards, which will result in severe personal injury or death.

WARNING

Watch for this symbol:



It Means: Hazards or unsafe practices, which could result in severe personal injury or death.

CAUTION

Watch for this symbol:



It Means: Hazards or unsafe practices, which may result in minor personal injury or product or property damage.



Watch for this symbol! It means BE ALERT! Your safety, or the safety of others, is involved!

Safety Notices and Decals



Failure to follow danger, warning, and caution instructions may lead to serious personal injury or death to operator or bystander or damage to property. Do not operate this machine until you read and understand all the dangers, warnings and cautions in this manual. For additional copies of either, or further information, contact:

Hennessy Industries, Inc.

1601 JP Hennessy Drive
LaVergne, TN 37086
(615) 641-7533 or (800) 688-6359
www.coatsgarage.com



⚠ WARNING	⚠ AVERTISSEMENT
<p>RISK OF EXPLOSION</p> <p>This equipment has internal arcing or sparking parts which should not be exposed to flammable vapors. Do not locate in a recessed area or below floor level.</p> <p>THIS EQUIPMENT MUST BE EARTH-GROUNDED</p> <p>The earth-ground connector built into the power cord provides protection to reduce the risk of electrical shock.</p>	<p>RISQUE D'EXPLOSION</p> <p>Cet équipement possède des pièces internes, pouvant lancer des arcs ou jeter des étincelles, et qui ne devraient pas être exposées à des vapeurs inflammables. Ne situez pas l'équipement dans des endroits encastrés ou en-dessous du niveau du plancher.</p> <p>CET ÉQUIPEMENT DOIT ÊTRE MIS À LA TERRE</p> <p>Le raccord de mise à la terre incorporé dans le cordon de puissance fournit une protection afin de réduire le risque d'électrocution.</p>
⚠ CAUTION	⚠ ATTENTION
<p>Do not use below garage floor or grade level.</p> <p>Disconnect power before servicing this equipment.</p> <p>To prevent electrical shock, do not remove cover. No user serviceable parts inside. Refer servicing to qualified service personnel.</p>	<p>N'utilisez pas en-dessous du plancher du garage ou du palier.</p> <p>Débranchez le cordon de puissance avant de faire l'entretien de cet équipement.</p> <p>Afin de vous protéger contre l'électrocution, n'enlevez pas le couvercle. Aucune pièce interne ne nécessite d'entretien par l'utilisateur. Référez l'entretien à un personnel de service qualifié.</p>

8113927 05

WARNING

Maximum Size of Wheel Rating

Weight	Diameter	Width
90 lbs./40 kg	42 in./107 cm	19 in./48cm

Maximum Duty Cycle

30 Wheels/Hour @ 90 lbs./40 kg

85610497 00

Saudi, Arabia Models Only

Standard Safety Devices



Never raise up the wheel guard before the wheel has come to a stop. Keep hair, loose clothing, fingers and all parts of body away from moving parts.

- STOP key for stopping the wheel under emergency conditions.
- A hood guard of high impact plastic that is designed to prevent the counterweights from flying out in any direction except towards the floor.
- A hood switch interlock system that prevents the machine from starting if the guard is not lowered and stops the wheel whenever the guard is raised.

WARNING

Maximum Size of Wheel Rating

Weight	Diameter	Width
150 lbs.	44 in.	20 in.

Maximum Duty Cycle

30 Wheels/Hour @ 150 lbs.

AVERTISSEMENT

**Capacité de la Dimension
Maximale de la Roue**

Poids	Diamètre	Largeur
68Kg	111,8cm	50,8cm

Cycle de Service Maximum

30 Roues/Heure @ 68Kg

85609404 00

WARNING

Risk of Injury

This machine is provided with a wheel guard interlock. Do not defeat it's purpose.

8111840 02

Table of Contents

Owner's Responsibility.....	iii	Direct Select™ Weight Location	12
Operator Protective Equipment	iii	Setting Wheel Dimensions (DIM).....	12
Definitions of Hazard Levels	iii	Definition of Dimensions (DIM)	12
Safety Notices and Decals	iv	Basic Wheel Data Entry	13
Standard Safety Devices	iv	Entering Wheel Dimensions Manually	13
Set Up Instructions	2	Balancing A Wheel.....	14
Receiving.....	2	Dynamic Balancing.....	14
Electrical Requirements	2	Static Balancing.....	14
Machine Set Up	2	Behind Spoke Mode.....	15
Floor and Space Requirements.....	2	Corrective Weight Placement	15
Connect to Power	2	Match Balance (Optimization)	16
Specifications.....	3	Match Balance Mode	16
Features.....	3	Calibration Program	17
Accessory Options.....	3	Machine Calibration.....	17
Basic Accessory Kit 85009974	3	Arm Calibration.....	18
★Balancing Your First Tire.....	4	Maintenance Instructions	19
Principle Operating Parts.....	5	Diagnostic Procedures	20
Know Your Unit.....	5	After Balance Vibration Problems.....	20
Power Switch	6	Troubleshooting.....	20
Using The Offset Arm.....	6	Glossary.....	22
Control Panel Layout.....	8		
Control Panel Function and Review	8		
Mounting Wheel On Balancer Shaft	10		
Standard Back Cone Mounting	10		
Standard Front Cone Mounting.....	11		
Alternate Mounting	11		

	 NOTICE
	<p style="text-align: center; margin: 0;">Read entire manual before assembling, installing, operating, or servicing this equipment.</p>

Set Up Instructions

Receiving

The shipment should be thoroughly inspected as soon as it is received. The signed bill of lading is acknowledgement, for the carrier, of receipt in good condition of the shipment covered by our invoice.

If any of the goods called for on this bill of lading are shorted or damaged, do not accept them until the carrier makes a notation of the shorted or damaged goods on the freight bill. Do this for your own protection.

NOTIFY THE CARRIER AT ONCE if any hidden loss or damage is discovered after receipt and request him to make an inspection. If the carrier will not do so, prepare an affidavit to the effect that you have so notified the carrier (on a certain date) and that he has failed to comply with your request.

IT IS DIFFICULT TO COLLECT FOR LOSS OR DAMAGE AFTER YOU HAVE GIVEN THE CARRIER A CLEAR RECEIPT.

File your claim with the carrier promptly. Support your claim with copies of the bill of lading, freight bill, invoice, and photographs, if possible.

Although COATS responsibility ceases upon delivery of the shipment to the carrier, we will gladly assist in tracing lost shipments. Our willingness to assist in every possible manner does not make COATS responsible for collection of claims, or replacement of lost or damaged materials.

Electrical Requirements

See serial tag for the appropriate power requirements of your machine.

Always have a qualified electrician install the proper receptacles in accordance with state and local codes.

Machine Set Up



Do not use the control panel, control panel base, accessory storage, faceplate, hood or shaft to lift the balancer.



Do not attempt to install and set up the unit yourself. Contact COATS as noted below.

A factory trained COATS Service Technician must perform the install, set up, and initial test procedures on your wheel balancer. Do not attempt to install and set up the unit yourself. Accurate and reliable operation of your unit depends on proper installation. Please contact COATS directly at 1-800-688-9240 for the Certified Service Partner nearest you.

Floor and Space Requirements

The balancer must be located on a flat floor of solid construction, preferably concrete. The balancer must sit solidly on its three feet. If the balancer is not level, does not sit solidly on its three feet, or is placed on an unstable floor, the balancer will not function properly and may produce inaccurate balance readings.

Do not operate the balancer while it is on the pallet.

Select a location for the balancer that provides a level, solid floor, and adequate clearance around and above the balancer. Make sure the location selected has enough room above and behind the unit so the hood can be raised completely. The location must also provide working room for mounting and removing wheels. Make sure the area has adequate lighting.

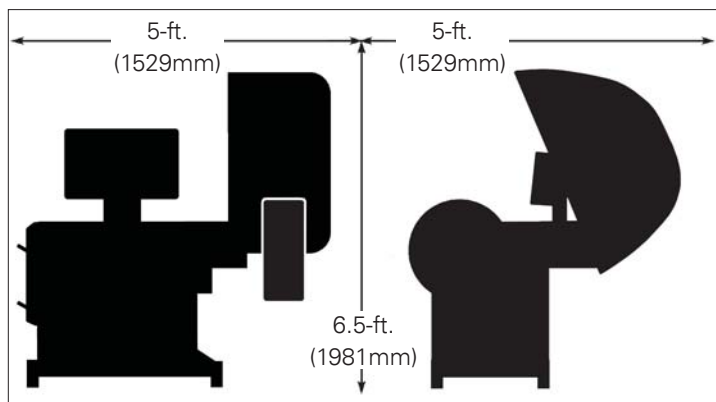

Figure 1 - Space Requirements

Connect to Power

Your factory trained COATS® Service Technician should do the final check to verify the power installation before connecting the balancer to a power supply. Failure due to improper power connection may void the warranty.

Specifications

Wheel Diameter Range

8 - 30 inches (203 - 762 mm)

Wheel Width Range

2 - 20 inches (51 - 508 mm)

Maximum Outside Tire Diameter

Up to 44 inches (1016 mm)

Maximum Tire/Wheel Weight

150 pounds (68 Kg)

90 pounds (40 Kg) Saudi Arabia

Mounting Shaft Diameter

40 mm

Resolution (Round Off Mode)

0.25 ounce, position 1.40 degrees

Resolution (Non-Round Off Mode)

0.01 ounce, position 1.40 degrees

Balancing Display Increments

0.25 or 0.01 ounces

Electrical Requirements

220V, 1 PH, 60 Hz, 20A

NEMA L6-20R

220V, 3 PH, 60 Hz, 20A

NEMA L15-20R

220V, 1PH, 60 Hz, 10A (Saudi Arabia)

240V, 1PH, 50 Hz, 10A (Australia)

(use grounding type plug)

Footprint

Depth: 60 inches (1524 mm)

Width: 60 inches (1524 mm)

Shipping Weight

680 pounds (308 Kg)

(with accessories)

Features

- Automatic Data Entry for Offset and Diameter - Manual Entry Backup on all Parameters.
- Static-on-Screen™
- Direct Select™ Weight Placement Location
 - Dynamic (Standard): Clip-on Weights
 - Alloy: User Defined
 - Static
- Behind the Spoke Weight Placement
- Automatic Start When Hood is Lowered
- Single Spin Balancing - Dynamic and Static
- Easy-To-Read Position Indicators
- Hood Safety Interlock System
- Extended Mounting Faceplate for Deeper Wheels
- Removable Center Shaft for Closed Center Wheels
- Match Balance (Optimization)
- Operator Memory for Two Different Users
- User Friendly Weight and Position Calibration
- No Bolt-down Installation
- Solid State Motor Control

Accessory Options

Basic Accessory Kit 85009974

- Small Cone
- Medium Cone
- Large Cone
- Light Truck Cone
- Rim Width Calipers
- Wheel Weight Pliers
- Hubnut Handle
- Small Pressure Cup & Rubber Lip
- Cone Spring
- Scraper
- Cone Peg Brackets

★Balancing Your First Tire

1. Turn the machine OFF then ON (resets machine).

The machine wakes up using standard clip-on wheel weight locations (Clip 1 & Clip 2) and wheel dimensions.

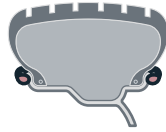

2. Mount a tire/wheel onto balancer that will use standard clip-on wheel weights.

Use the most appropriate mounting method.

3. Always remove any weights already attached to the wheel.

4. Enter A & D wheel dimensions using offset arm.

For Automatic Measurement — pull offset arm out to the wheel, hold it still at clip-on weight position against wheel flange, and wait for BEEP. Return arm to home position.

Clip-on Weight Location — viewed on a cut-away rim for clarification.



Figure 2 - Clip-On Weight Location

Note the value entry of A & D dimension.

5. Enter Width wheel dimension.

For Manual Entry — Use plastic calipers to measure wheel width. Press W key. Press Up or Down arrow to enter Width value (between 2.0 and 14.0 inches).

6. Lower Wheel Guard; wheel spins and unbalances are measured and displayed.

The corrective weight amount appears in the weight display window for inboard and outboard weight locations.

7. Raise hood after tire stops rotating.

Note: Wait for wheel to stop before raising the wheel guard.

8. Rotate wheel until Inboard weight position bar blinks.

Note: If an inboard corrective weight is not required then go to step 10.

9. Attach inboard corrective weight.

Attach specified weight amount at top-dead-center on inside flange of wheel (clip 1).

10. Rotate wheel until Outboard weight position bar blinks.

11. Attach outboard corrective weight.

Attach specified weight amount at top-dead-center on outside flange of wheel.

12. Lower the hood to respin the tire/wheel and check balance.

The weight readings should now be 0.00.

Note: Throughout this manual tire dimensions are referred to as A, W, and D, see figure 3.

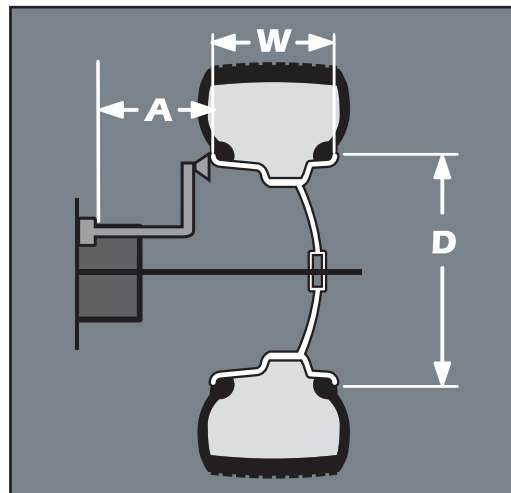

Figure 3 - A, W, and D Tire Dimensions

Principle Operating Parts

Know Your Unit

Compare this illustration with the unit before placing it into service. Maximum performance and safety will be obtained only when all persons using the unit are fully trained in its parts and operation. Each user should learn the function and location, of all controls.

Prevent accidents and injuries by ensuring the unit is properly installed, operated and maintained.

- A** - Control Panel
- B** - ON/OFF Switch (back of machine)
- C** - Plug (back of machine)
- D** - Weight Tray with Pockets for Weights
- E** - Offset Arm, Measures A & D of Tire/Wheel (Shown In Home Position)
- G** - 40 mm Shaft
- H** - Hood Guard



Note: Throughout this manual, wheel weights are referred to as Clip-on or Tape-A-Weight®. Figure 4 shows an example of each weight.



Clip-on Weight

Tape-A-Weight®

Figure 4 - Corrective Weight Examples. For Best Results, use BADA® Brand Wheel Weights.

Power Switch

The ON/OFF switch location (figure 5) is at the back of the balancer; below the weight tray.



Figure 5 - On/Off Switch

Using The Offset Arm

When not in use or when prompted by the balancer instructions, store the offset arm in the home position as shown in figure 6.

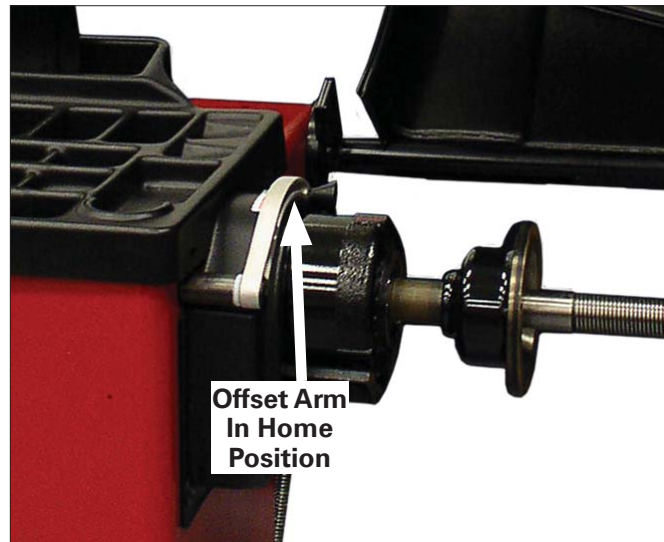

Figure 6 - Location of Offset Arm (Stored In Home Position)

When prompted by balancer instructions, use the offset arm (figure 6) to enter A & D measurements automatically. Pull the arm out and up against the wheel flange; hold it still at the clip-on weight location (figure 7), against the wheel flange, and wait for the BEEP.



Figure 7- Automatic A & D Measurement At Clip-on Weight Location

Be sure to place the offset arm on the wheel flange at the clip-on weight location as shown, figure 8.



Figure 8 - Clip-on Weight Location Viewed on a Cut-Away Rim for Clarification

Note: Use the offset arm to automatically measure the A & D dimension for all balancing modes.

Note: Refer to page 13 to measure the A dimension manually using the offset arm.

Note: The T2 Tape Direct™ Select Weight position is the only mode that requires the A2 & D2 dimension measurements.

If the T2 Tape (hidden Tape-A-Weight®) location is selected, use the offset arm to enter A2 & D2 measurements, automatically. After the A & D measurement is entered, move the arm from the clip-on weight location to the inner area of the wheel; up against the rim at the Outboard weight placement location (see figures 9 & 10). Wait for the BEEP.



Figure 9 - Hidden Weight Location Viewed on a Cut-Away Rim for Clarification

Important: The A2 measurement must be at least 2 inches greater than the A1 measurement.

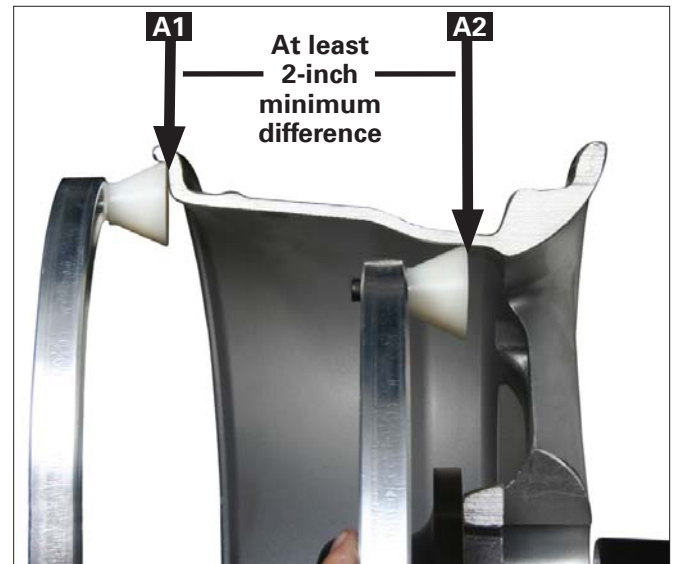

Figure 10 - T2 Tape (Hidden Tape-A-Weight®) Keep At Least 2-inches Between A1 and A2 Measurement

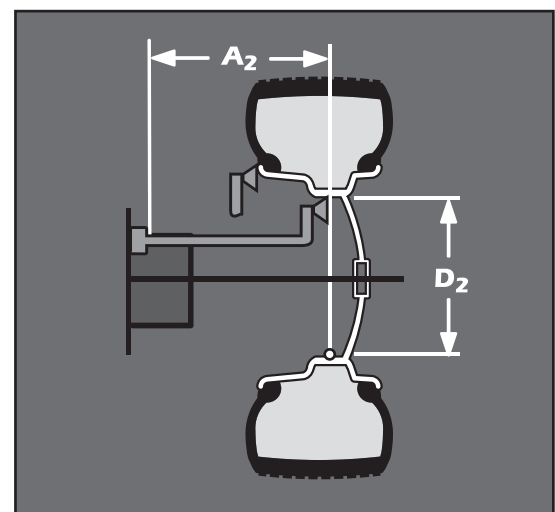

Figure 11 - T2 Tape (Hidden Tape-A-Weight®) Data Entry Diagram

Control Panel Layout

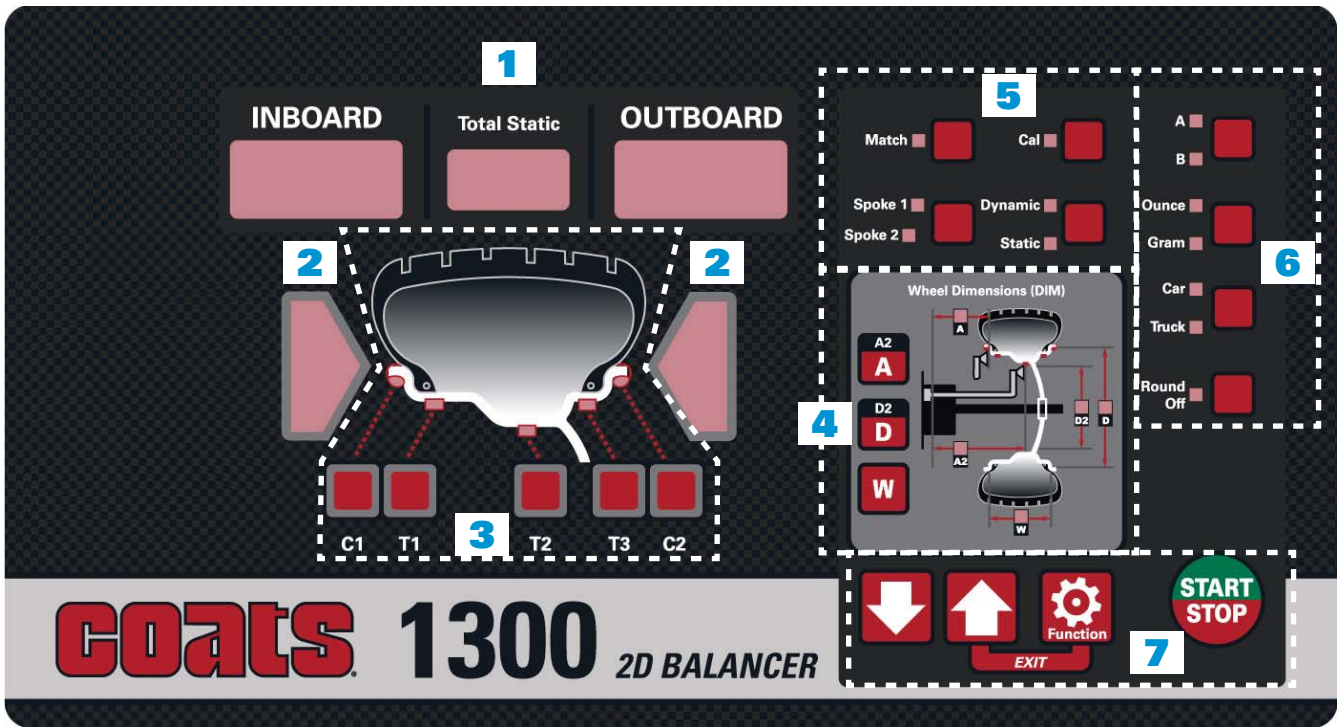

Figure 12 - Control Panel Feature Reference

Control Panel Function and Review

1 Weight Display Windows

Two weight display windows, one Inboard and one Outboard, are positioned above the Wheel Cross-section Diagram. After a wheel measurement cycle, the balancer calculates the corrective weight amount and indicates it in the appropriate display window. All weight readings are shown in Ounces or Grams. Also displays A, W, and D values, functions, and instructions for the operator. Error messages will also be shown in this display.





The Total Static window indicates the value of the total static unbalance. See MATCH BALANCE (Optimization) on page 16 for further details.

2 Weight Position Bars







Located on either side of the wheel cross-section diagram are the weight position bars, one Inboard and one Outboard. After a measurement cycle, rotate wheel until the center weight position bar blinks, indicating the correct weight placement position is at top-dead-center.











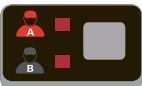

Key Group	If you press/select ...	Then indicator illuminates/displays...
-----------	-------------------------	--

3 Direct Select™ Weight Keys & Wheel Cross-section Diagram

 , or 	Clip 1, or T1 Tape	the activated Inboard weight location on the wheel cross-section diagram.
 ,  or 	T2 Tape, T3 Tape or Clip 2	the activated Outboard weight location on the wheel cross-section diagram.

4 Wheel Dimensions (DIM) Keys & Measurement Diagram

 ,  , or 	A, D, or W	the activated wheel measurement location. The default is Clip 1 and Clip 2. Enter wheel data manually using either the Up or Down arrow key.
 +  or  + 	A2+Function or D2+Function	

Key Group	If you press/select ...	Then indicator illuminates/displays...
5 Balance Mode Keys		
	Match	that Match Balance (Optimization) mode is activated.
	Spoke	that Behind Spoke mode is activated Toggle to activate / select location 1 or location 2 for adhesive weights.
	Calibration	that Machine Calibration mode is activated.
	Function+Calibration	that Arm Calibration mode is activated.
	Dynamic or Static	the Balance mode that is activated. Scroll to select Dynamic (default), Dynamic/Total Static or Static.
6 Balance Option Keys		
	A or B	the Operator Memory option that is activated. Toggle between two operator memories A (default) or B.
	Ounce or Gram	the weight measurement option that is activated. Toggle to select either Ounce (default) or Gram.
	Car or Light Truck	the weight increment option that is activated. Toggle to select either 0.25-ounce passenger car (default) or 0.50-ounce RV-Lt Truck (heavy wheels).
	Round Off	the weight increment option 0.25-ounce (default) is activated. Toggle off to select 0.01-ounce (fine).
7 Navigation Keys		
	Down Arrow or Up Arrow	the data entry values. Scroll to select desired value.
	Function	the activated function. Usually used in combination with another key.
	EXIT	that the function or error is deactivated.
	START / STOP	that measurement cycle is either begun (hood lowered) or is halted.

Mounting Wheel On Balancer Shaft



Avoid back injury, seek assistance when lifting heavy tire/rim assemblies onto the balancer shaft.



Failure to tighten the hub nut properly may result in the wheel dismounting, causing personal injury and property damage.

Select the most appropriate mounting method for the wheel you are balancing. Using the proper method ensures secure mounting and safe balancer operation, and prevents damage to the wheel.

On most wheels, the inner side of the wheel hub usually has the most uniform surface for wheel balancing. Always center the wheel by the most uniform shaped side of the hub to achieve the most accurate balance.

Regardless of mounting type, on standard units, always make sure that the wheel is forced firmly against the shaft faceplate and that the hub nut engages the threaded shaft for at least four complete turns. To assist in centering the wheel properly, rotate the wheel and the shaft while tightening the hub nut.

Standard Back Cone Mounting

Most original equipment and steel wheels can be mounted properly using this method. The wheel is centered on a cone from the inner side of the hub.

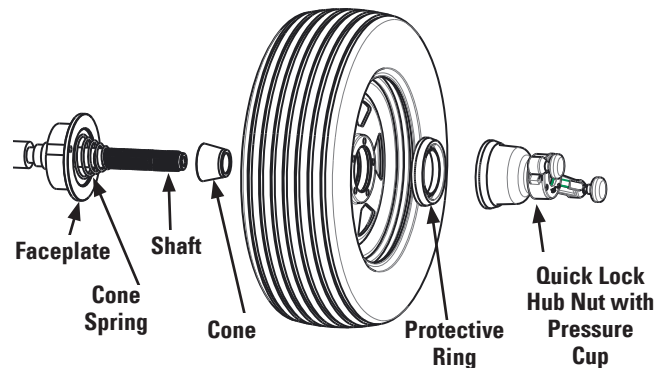

Figure 13 - Standard Back Cone Mounting

1. Place the cone spring onto the balancer shaft with the large end towards the faceplate.
2. Select the cone that best fits the center hole in the wheel. Slide the cone onto the shaft with the large end towards the cone spring.
3. Lift wheel onto the shaft and center it on the cone.
4. Attach pressure cup to hub nut. Install the hub nut assembly onto the shaft and tighten it securely against the wheel. The wheel must be forced firmly against the faceplate. The hub nut must engage the threads for at least four full turns

Note: Use a nylon spacer (protective ring) to protect custom wheel finishes.

Note: If the hub nut will not tighten completely, use the front cone mounting method.

Optional Front Cone/Collet Mounting

A wheel should be centered by the outer side of the hub only when the inner surface will not provide an accurate surface to center on.

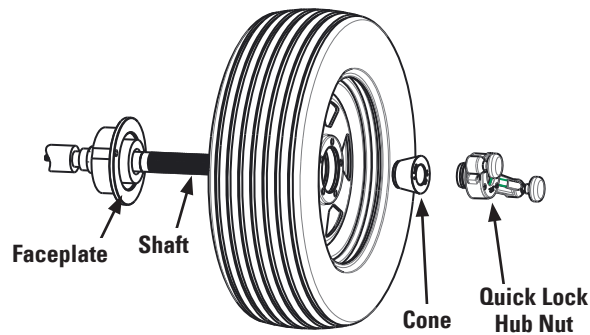

Figure 14 - Front Cone Mounting

1. Select the cone that best fits the center hole in the wheel.
2. Lift the wheel onto the balancer shaft and slide it back against the faceplate.
3. Slide the cone onto the shaft and into the center hole of the wheel. You will need to lift the tire to seat the cone in the center hole.
4. Install the hub nut (without pressure cup) onto the shaft. Tighten it securely against the cone. The hub nut must engage the threads for at least four full turns.

Note: If the hub nut will not tighten completely because of a lack of threads, use an additional cone as a spacer between the mounting cone and the hub nut. The wheel must be forced firmly against the faceplate.

Note: Do Not front cone chrome or clad wheels.

Alternate Mounting

If the wheel has a protruding outer hub which will not permit the use of the pressure cup, or the cup will not permit the hub nut to engage at least four turns of the shaft, this alternate method should be used.

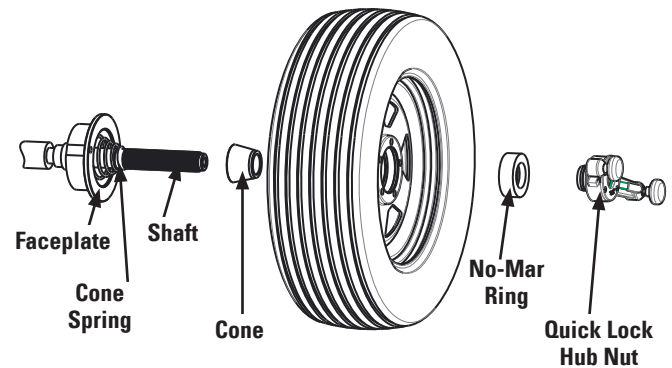

Figure 15 - Alternate Mounting

1. Place the cone spring onto the balancer shaft with the large end towards the faceplate.
2. Select the cone that best fits the center hole in the wheel. Slide the cone onto the shaft with the large end towards the faceplate.
3. Lift wheel onto the shaft and center it on the cone.
4. Use the small nylon spacer (no-mar ring) or a centering cone to press against the outer wheel hub.
5. Install the hub nut (without the pressure cup) onto the shaft. Tighten securely.

Direct Select™ Weight Location

Before spinning the wheel, use direct select to indicate weight placement locations on the wheel as follows:

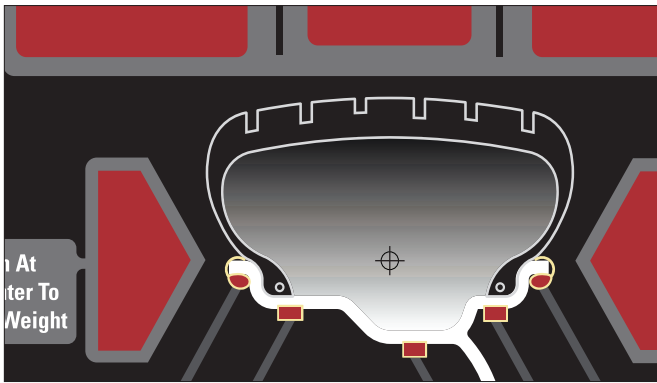

Figure 16 - Direct Select™ Weight Keys & Wheel Cross-section Diagram

Note: When the machine is turned ON, the balancer defaults to a 2-plane dynamic mode using standard clip-on wheel weight locations (Clip 1 and Clip 2) and wheel dimensions.

Clip 1 (default) - select this location to place a standard clip weight on the Inboard rim flange.

T1 Tape - select this location to place an adhesive weight on the Inboard side of the wheel that is the horizontal plane at the outer edge.

T2 Tape - select this location to place an adhesive (hidden) weight on the Outboard side of the wheel that is the horizontal plane in the inner area.

T3 Tape - select this location to place an adhesive weight on the Outboard side of the wheel that is the horizontal plane at the outer edge.

Clip 2 (default) - select this location to place a standard clip weight on the Outboard rim flange.

Setting Wheel Dimensions (DIM)

Before a wheel can be balanced, wheel dimensions must be entered into the computer.

Definition of Dimensions (DIM)

A = Offset

The distance measured from the balancer ("0" on offset arm) to inner plane of the rim (inner weight location).

W = Width

The width of the wheel at the rim flanges, measured with the calipers as shown in figure 19.

Note: Only use calipers provided by the wheel balancer manufacturer because others may not be the same.

D = Diameter

The diameter of the wheel as indicated on the tire.

Note: A thick flange, on some aluminum wheels, can effect the measured diameter. For example, a 16-inch rim can have a measured diameter of 15.5-inches.

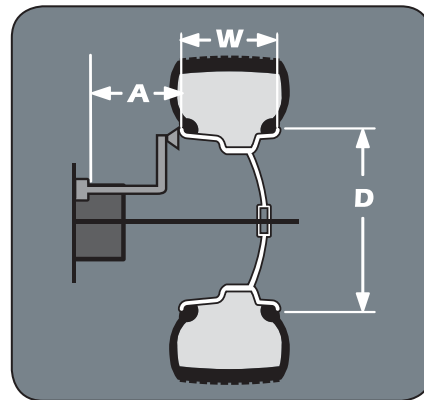

Figure 17 - W, D, and A Tire Dimensions

A2 = Offset

The distance measured from the balancer ("0" on offset arm) to outer plane of the rim (outer weight location). Used only for adhesive weight location.

D2 = Diameter

The diameter as measured at the A2 weight location. Used only for adhesive weight location.

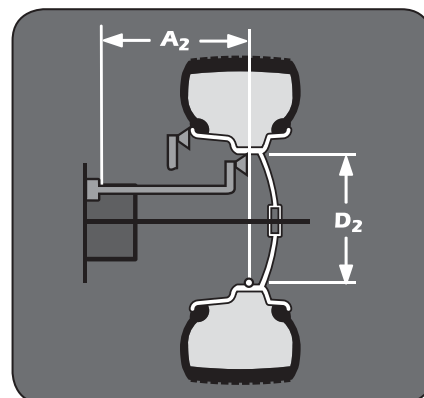

Figure 18 - A2 and D2 Tire Dimensions

Basic Wheel Data Entry

1. Direct Select™ an Inboard weight location (Clip 1, or T1 Tape) and an Outboard weight location (T2 Tape, T3 Tape or Clip 2).

2. Position offset arm at clip weight location; wait for BEEP (A & D enters automatically).

If the T2 Tape location is selected, then move the offset arm from the clip weight location to the inner area of the wheel; up against the rim at the outboard weight placement location; wait for BEEP (A2 & D2 enters automatically).

3. Return offset arm to the home position.

4. Use caliper and measurement rim width.

5. Use UP / DOWN arrows to adjust the W (Width DIM) to match measured caliper width of mounted rim.

6. Lower hood and spin wheel.

Entering Wheel Dimensions Manually

Information entered into the balancer software for A, W, and D can be changed anytime during a balancing procedure by entering the measurements manually. The balancer will recalculate weights and positions based on the new measurements.

Wheel Offset - A

1. Press the A (wheel offset) key.

2. Position offset arm at weight location on wheel and read the number on the offset arm gauge, at the cabinet (this is the correct offset A DIM).

3. Use UP / DOWN arrow to adjust the measurement.

Wheel Diameter - D

1. Press the D (wheel diameter) key.

2. Inspect mounted tire sidewall to determine the exact diameter this is printed on the tire.

3. Use the UP / DOWN arrow to adjust the D (Diameter DIM) to match the tire sidewall size.

Note: Auto entry is the preferred method for entering A2 and D2. However, to manually enter A2, press Function+A and hold. And to enter D2, press Function+D and hold.

Wheel Width - W

1. Press the W (wheel width) key.

2. Use the plastic calipers provided with the wheel balancer to measure the wheel width.



Figure 19 - Caliper Placement On Wheel

3. Use UP / DOWN arrows to adjust the W (Width DIM) to match measured caliper width of mounted rim.

Balancing A Wheel

A variety of wheel configurations can be balanced using this wheel balancer. Read through this section, it will help in determining which balancing mode and options are best suited for certain wheel assemblies.

Remember: As with any balancing procedure, first remove any weights attached to the wheel, inspect the tire and wheel, and use the most appropriate balancer mounting method before beginning.

Dynamic Balancing

Choose a dynamic balance to balance a wheel using two planes for correction. Select the weight option that best fits the available weight locations on the rim.

Clip-on Weights - The standard default; used for most passenger tire/wheel assemblies using the most common location for corrective weights. Clip-on weights are placed on the inner (inboard) and outer (outboard) rim flanges.

ALUS (Aluminum Wheels) - To balance aluminium wheels you usually use a self-adhesive weight location that is positioned differently from the clip-on weight position(s) used in standard balancing. Be sure to use the appropriate wheel data entry method since the balancer calculates out of balance values based on the wheel dimension measurements (DIM) entered for the tire/wheel assembly.

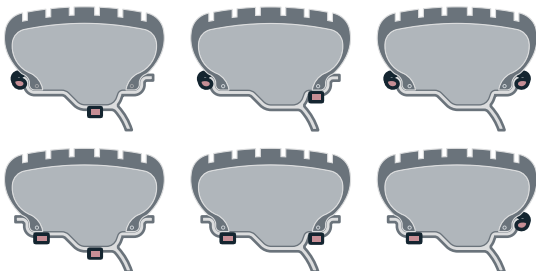

Figure 20 - Dynamic Balance Weight Locations

Note: When the machine is switched on, a standard dynamic balance using clip-on weight locations is the default setting.

Static Balancing

Choose a static balance to balance a wheel using one plane for correction. Place the single corrective weight at top-dead-center (12 o'clock) on either flange, at the center of the rim channel, placed inward either side, or split on either sides.

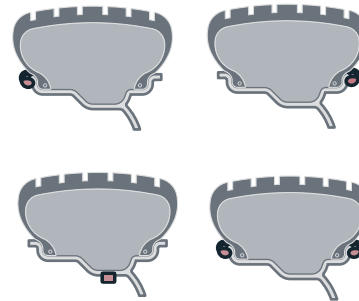

Figure 21 - Static Balance Weight Locations

Note: When in static mode, you only need to input the DIAMETER wheel measurement.

Important: If you decide to use the rim channel for corrective weight placement, remember you may need to adjust the DIAMETER measurement input. Typically you would make it 2 or 3 inches less than the actual tire/wheel diameter.

Behind Spoke Mode

"Splitting" the T2 Tape corrective weight amount is used to hide the adhesive weight behind two rim spokes.

- 1.** When the unbalance is displayed, rotate wheel until Inboard center bar blinks. Attach Inboard corrective weight at top-dead-center.
- 2.** Next, rotate wheel until the outboard center bar blinks.
- 3.** Select the Behind Spoke mode option. "SP1" will display in the static display window.
- 4.** Rotate the wheel toward front until the first spoke is at top-dead-center.; press Spoke and 1 illuminates. "SP2" will display in the static display window.
- 5.** Rotate the wheel toward rear until the second spoke is at top-dead-center; press Spoke and 2 illuminates. Now at the Spoke 2 location, the Outboard center bar stops blinking.

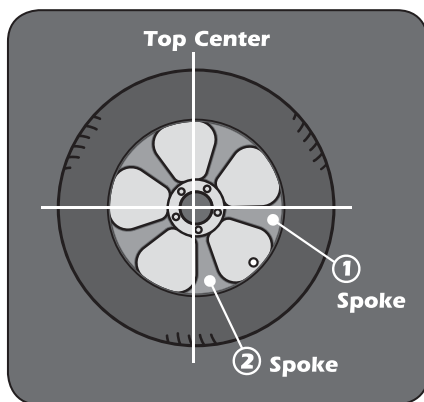

Figure 22 - Spoke 1 and Spoke 2 Locations On Either Side Of Original Outboard Weight Location

- 6.** Attach the Spoke 2 Outboard corrective weight at top-dead-center behind spoke 2.
- 7.** Next, rotate the wheel toward the Spoke 1 location until the outboard center bar is blinking.
- 8.** Attach the Spoke 1 Outboard corrective weight at top-dead-center behind spoke 1.
- 9.** Respin tire/wheel to check balance.

Corrective Weight Placement

After the wheel spins and out of balances are measured and displayed, the corrective weight amount appears on the weight display window for Inboard and Outboard weight locations. Bars appear on either side of the wheel cross-section diagram to aid in positioning the wheel for corrective weight at the application point.

After a measurement cycle, rotate wheel until the center weight position bar blinks, indicating the correct weight placement position is at top-dead-center. If the out-of-balance is less than the chosen threshold value, 000 appears instead of an out-of-balance value to indicate that, on that particular side, the wheel is in tolerance.

Match Balance (Optimization)



Match Balance involves the loosening of tire beads and the inflation of a tire. Training is necessary in tire changer operation and understanding the dangers involved during bead seating and tire inflation before attempting this stage of the Match Balance procedure. Read the operators manual supplied with the tire changer and consult a supervisor.

Use the Match Balance (Tire/Rim Weight Optimization) program to determine the best mating of tire and rim that will result in the least amount of total unbalance of the assembly. It requires two spins and two rotations of the tire on the rim. Match Balance may be needed when:

- The customer complains of ride problems.
- The balancer calculates a high out of balance.
- The balancer calls for Total Static weights in excess of 3 ounces (85 grams) on passenger car tires.

Important: A high unbalance may indicate the improper mounting of the assembly on the balancer, or a rim that is out of round or misformed, or a tire with a bubble or other problem. If the unbalance is excessive, it may be prudent to replace the rim, the tire, or both. If either is replaced, do not continue with Match Balance. Balance the new tire and rim and evaluate the readings.

Match Balance Mode

If you choose to use Match Balance to correct for a condition, such as a large static unbalance, then follow the machine prompts and instructions for the MATCH BALANCE procedure as outlined in the following steps.

Note: Use this procedure only after the wheel has spun and the corrective weight amount is displayed.

Note: Use the Total Static display option. See Balance Options, page 14, for further details.

1. Press Match to select the Match Balance mode. A "1" will appear in the Outboard weight display.

2. Raise the hood and rotate the wheel until the valve stem is at top-dead-center. Mark the tire sidewall at the valve stem.

3. Press Function on the control panel; a "2" will appear in the Outboard weight display.

4. Remove the wheel assembly from the balancer.

5. Using a tire changer, rotate the tire 180 degrees on the rim.

6. Remount wheel assembly on the balancer. Press Function on the control panel; a "3" will appear in the Outboard weight display.

7. Lower the hood. The wheel spins; a "4" will appear in the Outboard weight display.

8. When the wheel stops spinning, raise the hood and rotate the wheel until the valve stem is at top-dead-center.

9. Press Function on the control panel. Weight amounts appear on the control panel.

The amount in the Inboard weight display is the weight imbalance for the rim. The amount in the Outboard weight display is the weight imbalance for the tire. Use these weight amounts to determine the suitability of the rim or tire.

Note: If either the rim or the tire weight amount is close to zero or zero then using Match Balance will not affect the total unbalance of the assembly.

10. Rotate the wheel until the Outboard weight position bar flashes. Mark the tire at top-dead-center.

11. Remove wheel assembly from balancer.

12. Using a tire changer, rotate the tire until the mark is aligned with the valve stem.

13. Remount the wheel assembly on the balancer.

14. Press Function to exit Match Balance. Select a balancing mode and balance the wheel assembly.

Calibration Program

Important: Be sure to use the correct calibration weight amount: a 4-ounce calibration weight with the ounce option or a 100-gram calibration weight with the gram option activated. Be sure to deactivate the Round Off option.

Machine Calibration

For machine calibration, proceed as follows:

1. Mount a 14, 15, or 16-inch steel tire/wheel assembly on the balancer. A balanced tire/wheel is required.

Note: Position wheel so that no weights are on either flange at the top-dead-center location. Turn the machine OFF then ON.

2. Press and hold Calibration key for three (3) seconds to select Machine Calibration mode.

3. Press "D" key to enter the D (diameter) dimension. Press the Up and/or Down arrow key to adjust numbers. A valid data entry is either "14", "15", or "16".

4. Press the Function key.

5. Lower the hood and press the START key to begin the measurement cycle.

6. After the tire/wheel stops spinning, raise the hood.

7. Rotate wheel until the Outboard center bar blinks. Attach calibration weight (either 4-ounce or 100 gram) to the outboard flange at top-dead-center.



Figure 24 - Calibration Weight On Outboard Flange At Top-Dead-Center

8. Lower the hood and press the START key to begin the measurement cycle.

9. After the tire/wheel stops spinning, raise the hood.

10. Rotate wheel until the Inboard center bar blinks. Move and attach the 100-gram calibration weight to the inside flange at top-dead-center.

Important: It is critical that the inner weight be placed accurately to achieve proper calibration. If the calibration weight is not moved from the outside flange directly across to the inside flange, an inner weight placement error will occur and the calibration will be "failed".



Figure 25 - Calibration Weight On Inboard Flange At Top-Dead-Center

11. Lower the hood and press the START key to begin the measurement cycle.

12. After the tire/wheel stops spinning, machine displays "100, END CAL". Machine Calibration is complete.

13. Press FUNCTION to exit.

Arm Calibration

Important: Always perform the Arm Calibration immediately after Machine Calibration. The balancer software will not permit it otherwise. During Machine Calibration, the balancer software calculates both the A (offset) and W (width) dimensions. The Arm Calibration gives the balancer software a reference point to the edge of the faceplate and home position. When the user enters the A dimension from the arm rod, it calculates the difference from the Machine Calibration A and uses that as a factor for the manual A entry. Arm Calibration also gives the D dimension a reference point from home position.

1. Complete the Machine Calibration procedure (see page 17).

2. Press and hold the Function key and Calibration key for three (3) seconds to select the Arm Calibration mode.

3. Bring the tip edge of the arm precisely to the outer edge of the faceplate and hold it there while pressing the Function key. If necessary to reach the faceplate accurately, loosen the calibration wheel temporarily.

4. With the arm still at the edge of the faceplate, press A key and use UP / DOWN arrow to adjust A dimension value as shown on arm gauge. Display will show at static position of LED. Press Function key.

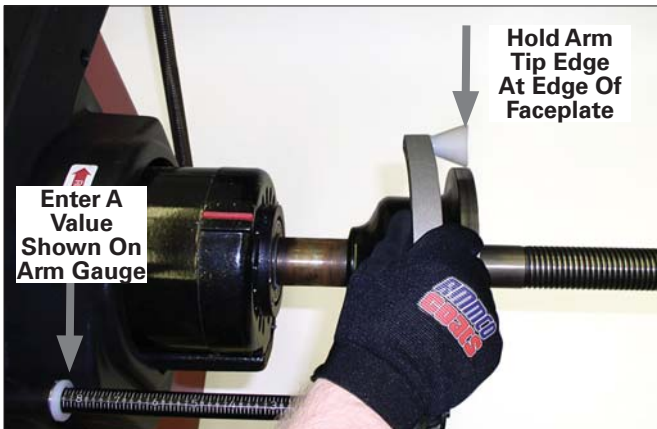

Figure 26 - While holding Arm At Faceplate Edge, Enter A

5. Move the arm to its home position and press the Function key.

6. Move the arm to the clip-on weight location on the rim flange and hold it there; press D key and use UP / DOWN arrows to adjust the D dimension value. Display will show at static position of LED. Press Function key.

7. While still holding the arm at the clip-on weight position on the wheel, press A key and use UP / DOWN arrows to adjust the A dimension value as read off the arm gauge. Press Function key.

8. Return arm to home position.

9. When machine displays "END", the Arm Calibration is complete. Press FUNCTION to exit.

Important: To redo the Arm Calibration procedure, press and hold FUNCTION and press "Clip 1" for 3 seconds to enter CDE mode, then press "T1 Tape" then press "W" to bypass the Machine Calibration requirement. Always use the same wheel assembly that was used during the Machine Calibration or else the calibration will not be correct.

Maintenance Instructions



Use caution, this is an electrical device. Exposing the balancer to water, either by hose or bucket, or by exposure to rain or snow, may cause risk of shock or electrocution to operator or bystanders. Place, store, and operate the balancer only in a dry, sheltered location.



Do not hose down with water or bucket wash the balancer. Extensive damage to the balancer will result. Sensitive electronic components, wiring harnesses, and other devices housed in the balancer are not intended to be exposed to water.

The balancer requires only minor maintenance to keep the unit operating properly.

1. Keep the display clean and clear. Use a damp cloth. Do not use cleaners or solvents which leave oily or filmy residues behind.

2. Keep the adapters, cones, faceplate, threaded shaft, pressure cup, and hub nut clean. Grease and dirt buildup will cause inaccurate balancing and premature wear. Clean these items at least once a day with a vaporizing solvent.

3. Clean weight tray and any accessory posts, pegs, or storage shelves with a vaporizing solvent. Weights stored in a dirty tray may pick up grease and dirt which may keep them from securely attaching to the wheel.

4. Keep the area around and under the balancer clear. Remove any tools or other items that are leaning against the balancer. Remove any items that may cause the balancer to not sit level. Be particularly cautious of new or used wheel weights on the floor, as they may cause personal injury due to falls.

5. Use only COATS® accessories. Accessories from other manufacturers may not fit or function properly, and may damage the balancer.

Important: Always be sure to remove the wheel assembly from the pneumatic shaft before disconnecting the air supply from the machine.

Diagnostic Procedures

After Balance Vibration Problems

If vibration is still present after balancing the wheels and driving the vehicle on smooth pavement, remove the wheels and recheck the balance. If a wheel is out of balance the cause maybe:

- Wheel was not mounted/centered correctly on the balancer.
- A weight has come off the wheel (possibly the wrong clip style). Remove the other weights from the wheel and rebalance.
- Foreign material inside the tire. Remove the tire from the wheel, remove the foreign material, and remount. Remove wheel weights and rebalance the wheel.
- Stones or other foreign objects caught in the tire tread or rim. Remove the objects. Check and rebalance if needed.

If the balancer still indicates the wheels are balanced to within 0.05 ounces (1.42 grams) on both Inboard and Outboard displays, the problem is not in the balance of the wheels. Check the following possible sources of vibration:

- Tire pressure. Bring all tires up to the recommended PSI.
- Radial or lateral runout in the tire or wheel. Replace the damaged part.
- Unbalance in wheel covers or trim rings. Remove the wheel covers or trim rings and test drive. If the vibration is gone, remove the shaft and use an appropriate adapter to mount the wheel to the balancer. Balance the wheel with the wheel cover or trim ring attached to the wheel.
- Incorrectly mounted tire and wheel. Remount correctly.
- Damaged wheel bolt holes. Replace wheel.
- Worn universal joints. Replace as required.
- Drive shaft unbalance or damaged. Balance, repair, or replace.
- Unbalance in brake rotor(s) or drum(s).
- Suspension out of alignment. Align the vehicle and replace any damaged or worn parts.

Troubleshooting

A COATS® Service Technician may ask for information to help diagnose service concerns (please contact COATS directly at 1-800-688-9240 for the Certified Service Partner nearest you). Conveying this information to your service technician prior to servicing can help to expedite service to your equipment. Although much of the diagnostic information aids your COATS Service Technician, several remedies for balancer misfunctions are available to the operator.

Error Messages - One of the following error messages, shown in the display windows, may appear indicating a problem with the balancer.

Note: Always exit the error message by pressing the Up arrow+Function key; then repeat the procedure to see if the error is eliminated.

Error	Description
E1	Spin up is too slow - Verify power supply to balancer and motor connection
E2	Spin up time too long - Check Wheel DIA and power supply - press STOP - EXIT
E3	No rotation signal - Check motor & encoder function & wiring -press STOP - EXIT
E4	Wheel rotation direction is reversed - Disconnect power and correct wiring
E5	Stop time too long - Verify power supply and motor connection - press STOP - EXIT
E6	Encoder is not connected or has failed - Disconnect power supply and repair
E9	Wheel coast speed is too slow
E11	User cancelled the operation
E20	Arm scale is out of range
E24	Lower hood to spin
E25	Loose hub nut. Tighten hub nut and respin
E26	CAL ERROR
Err Hod	Hood switch is not closed when machine cycle is started - Lower hood to spin - Verify hood switch
Err Hub	No load condition detected - Verify wheel mounted properly on the shaft - Check repeatability
Err Ad	No dimension input

Error	Description
100, N01, CAL	Exceeded 5 degree range between placement of calibration weight from outside flange to inside flange.
100, N02, CAL	Calibration wheel is more than 1-ounce out of balance. Calibration is rejected.
100, N03, CAL	Calibration wheel is more than 0.25-ounce but less than 1-ounce out of balance. Calibration is stored, but with warning.

Overload Protection - The balancer's motor is overload protected per UL requirements. After 4 to 5 minutes the machine automatically resets itself; activating the fan motor. If this happens, notify your Certified Service Partner immediately.

Important: Allow the fan to cool the motor for at least 30 minutes before using the balancer so the overload protection is not tripped again.

Glossary

ALUS -Alloy wheel mode that typically requires the use of one or two adhesive weights for correction.

Balancer Flange – Disk that mates with the disk of the wheel mounted to the balancer. The flange also serves to keep the wheel perfectly perpendicular to its axis of rotation.

Balancing Cycle – Sequence of operations performed by the user and the machine, beginning from the start of the wheel spin to the time that the wheel is braked to a standstill after the out of balance signals are acquired and the relative values calculated.

Centering – Procedure for positioning the wheel on the spindle shaft with the aim of ensuring that the rotational axis of the wheel is aligned with the center of the shaft.

Centering Flange (accessory) – Device serving to support and center the wheel. Also keeps the wheel perfectly perpendicular to its axis of rotation. The centering flange is mounted to the balancer shaft by means of its center hole.

Cone – Conical components with center hole. When inserted on the spin shaft, serves to center wheels with centre holes whose diameter is between maximum and minimum values.

Dynamic Balancing – Operation in which out of balance is corrected by the application of two weights, one on each side of the wheel.

Self-calibration – A procedure whereby suitable correction coefficients are calculated by starting from known operating conditions. Self-calibration improves the measurement precision of the machine by correcting, within limits, calculation errors that may arise due to alteration of the machine's characteristic over the course of time.

Spin – Procedure starting from the action that causes the wheel to rotate and the successive free rotation of the wheel.

Quick Nut – Device for clamping the wheel to the balancer. The hubnut features elements for engaging to the threaded hub and lateral pins that are used to tighten it.

Static Balancing – In static balancing only the static component of out of balance is corrected. This is achieved by fitting a single weight, usually at the center of the rim channel. The accuracy of this system increases as the width of the wheel decreases.

Threaded Hub – Threaded part of the shaft that is engaged with the hubnut to clamp the wheel. This component is supplied disassembled from the machine.

Out of balance – Non-uniform distribution of the wheel mass that results in the generation of centrifugal force during rotation.

